



[CEN/TC 239](#)

Rescue systems

Email of Secretary: harry.schmidt@din.de

Secretariat: DIN

Final draft prEN 1789_(E)_Nov06

Date of document 2006-10-05

Expected action Info

Background

Final Draft prEN 1789 "Medical vehicles and their equipment - Road ambulances"

CEN Member bodies are requested to vote in the voting period

November 2006

ICS 11.160; 43.160

Will supersede EN 1789:1999

English Version

Medical vehicles and their equipment - Road ambulances

Véhicules de transport sanitaire et leurs équipements -
Véhicule d'ambulances

Rettungsdienstfahrzeuge und deren Ausrüstung -
Krankenkraftwagen

This draft European Standard is submitted to CEN members for formal vote. It has been drawn up by the Technical Committee CEN/TC 239.

If this draft becomes a European Standard, CEN members are bound to comply with the CEN/CENELEC Internal Regulations which stipulate the conditions for giving this European Standard the status of a national standard without any alteration.

This draft European Standard was established by CEN in three official versions (English, French, German). A version in any other language made by translation under the responsibility of a CEN member into its own language and notified to the Management Centre has the same status as the official versions.

CEN members are the national standards bodies of Austria, Belgium, Cyprus, Czech Republic, Denmark, Estonia, Finland, France, Germany, Greece, Hungary, Iceland, Ireland, Italy, Latvia, Lithuania, Luxembourg, Malta, Netherlands, Norway, Poland, Portugal, Romania, Slovakia, Slovenia, Spain, Sweden, Switzerland and United Kingdom.

Warning : This document is not a European Standard. It is distributed for review and comments. It is subject to change without notice and shall not be referred to as a European Standard.



EUROPEAN COMMITTEE FOR STANDARDIZATION
COMITÉ EUROPÉEN DE NORMALISATION
EUROPÄISCHES KOMITEE FÜR NORMUNG

Management Centre: rue de Stassart, 36 B-1050 Brussels

Contents

Page

Foreword.....	4
1 Scope	5
2 Normative references	5
3 Terms and definitions	7
4 Requirements	8
4.1 General requirements.....	8
4.1.1 General.....	8
4.1.2 Maximum overall dimension.....	9
4.1.3 Wheel arch clearance	9
4.2 Performance	9
4.2.1 Acceleration	9
4.2.2 Braking.....	9
4.2.3 Safety system.....	9
4.3 Electrical requirements	9
4.3.1 General.....	9
4.3.2 Electromagnetic compatibility (EMC)	9
4.3.3 Battery and alternator	10
4.3.4 Electrical installation.....	11
4.4 Vehicle body.....	12
4.4.1 Fire safety.....	12
4.4.2 Driver's seat configuration	12
4.4.3 Minimum loading capacity.....	12
4.4.4 Bulkhead	12
4.4.5 Openings (doors, windows, emergency exits)	12
4.4.6 Loading area.....	13
4.5 Patient's compartment	14
4.5.1 General.....	14
4.5.2 Patient's compartment dimensions	15
4.5.3 Patient and attendant seating.....	21
4.5.4 Ventilation and anaesthetic gas scavenging systems.....	21
4.5.5 Temperature system.....	22
4.5.6 Interior lighting.....	22
4.5.7 Interior noise level	23
4.5.8 Holding system for infusion	23
4.5.9 Mounting systems	23
5 Testing	24
5.1 Testing of the interior noise level	24
5.2 Testing of the acceleration	24
5.3 Testing of maintain systems and fixations of the equipment in the patient's compartment	24
5.4 Testing of rounded edges.....	26
6 Medical devices.....	27
6.1 Provision of medical devices	27
6.2 Medical devices storage	27
6.3 Requirements for medical devices	28
6.3.1 General.....	28
6.3.2 Temperature	28
6.3.3 Humidity and ingress of liquids	28
6.3.4 Mechanical strength	28
6.3.5 Fixation of devices.....	29

6.3.6	Electrical safety	29
6.3.7	User interface	29
6.3.8	Gas installation	29
6.3.9	Marking and instructions	31
6.3.10	Maintenance	31
6.4	Mechanical strength – Test methods for medical devices for use in road ambulances	31
6.4.1	Vibration and bump test	31
6.4.2	Free fall	32
6.5	List of equipment	32
Annex A (informative)	Recognition	39
A.1	Recognition and visibility of ambulances	39
A.2	Recognition of personnel	39
Annex B (informative)	Test summary	40
Annex C (informative)	Certificate of compliance	41
Annex ZA (informative)	Relationship between this European Standard and the Essential Requirements of EU Directive 93/42/EEC concerning medical devices	42
	Bibliography	43

Foreword

This document (prEN 1789:2006) has been prepared by Technical Committee CEN/TC 239 “Rescue systems”, the secretariat of which is held by DIN.

This document is currently submitted to the Formal Vote.

This document will supersede EN 1789:1999.

This document has been prepared under a mandate given to CEN by the European Commission and the European Free Trade Association, and supports essential requirements of EU Directive(s).

For relationship with EU Directive(s), see informative Annex ZA, which is an integral part of this document.

1 Scope

This European Standard specifies requirements for the design, testing, performance and equipping of road ambulances used for the transport and care of patients. It contains requirements for the patient's compartment.

This European Standard does not cover the requirements for approval and registration of the vehicle and the training of the staff which is the responsibility of the authority/authorities in the country where the ambulance is to be registered.

This European Standard is applicable to road ambulances capable of transporting at least one person on a stretcher.

Requirements are specified for categories of road ambulances based in increasing order of the level of treatment that can be carried out. These are the patient transport ambulance (types A₁ A₂), the emergency ambulance (type B) and the mobile intensive care unit (type C).

This European Standard gives general requirements for medical devices carried in road ambulances and used therein and outside hospitals and clinics in situations where the ambient conditions can differ from normal indoor conditions.

2 Normative references

The following referenced documents are indispensable for the application of this document. For dated references, only the edition cited applies. For undated references, the latest edition of the referenced document (including any amendments) applies.

EN 3-7, *Portable fire extinguishers — Part 7: Characteristics, performance requirements and test methods*

EN 420, *Protective gloves — General requirements and test methods*

EN 455-1, *Medical gloves for single use — Part 1: Requirements and testing for freedom from holes*

EN 455-2, *Medical gloves for single use — Part 2: Requirements and testing for physical properties*

EN 471:2003, *High-visibility warning clothing for professional use — Test methods and requirements*

EN 737-1:1998, *Medical gas pipeline systems — Part 1: Terminal units for compressed medical gases and vacuum*

EN 737-3:1998, *Medical gas pipeline systems — Part 3: Pipelines for compressed medical gases and vacuum*

EN 739, *Low-pressure hose assemblies for use with medical gases*

EN 794-3, *Lung ventilators — Part 3: Particular requirements for emergency and transport ventilators*

EN 864, *Medical electrical equipment — Capnometers for use with humans — Particular requirements*

EN 980, *Graphical symbols for use in the labelling of medical devices*

EN 1041, *Information supplied by the manufacturer with medical devices*

EN 1865, *Specifications for stretchers and other patient handling equipment used in ambulances*

EN 12470-1, *Clinical thermometers — Part 1: Metallic liquid-in-glass thermometers with maximum device*

EN 13544-1, *Respiratory therapy equipment — Part 1: Nebulizing systems and their components*

prEN 1789:2006 (E)

EN 14052, *High performance industrial helmets*

EN 60068-2-6, *Environmental testing — Part 2: Tests — Tests Fc: Vibration (sinusoidal) (IEC 60068-2-6:1995 + Corrigendum 1995)*

EN 60068-2-29, *Basic environmental testing procedures — Part 2: Tests; test Eb and guidance: bump (IEC 60068-2-29:1987)*

EN 60068-2-32, *Basic environmental testing procedures — Part 2: Tests; test Ed: free fall (IEC 60068-2-32:1975 + A1:1982 + A2:1990)*

EN 60068-2-64, *Environmental testing — Part 2: Test methods — Test Fh: Vibration, broad-band random (digital control) and guidance (IEC 60068-2-64:1993 + Corrigendum 1993)*

EN 60601-1 (all parts), *Medical electrical equipment*

EN 60601-2 (all parts), *Medical electrical equipment*

EN 60601-2-4, *Medical electrical equipment — Part 2-4: Particular requirements for the safety of cardiac defibrillators (IEC 60601-2-4:2002)*

EN ISO 407, *Small medical gas cylinders — PIN-index yoke- type valve connections (ISO 407:2004)*

EN ISO 9919, *Medical electrical equipment — Particular requirements for the basic safety and essential performance of pulse oximeter equipment for medical use (ISO 9919:2005)*

EN ISO 10079-1:1999, *Medical suction equipment — Part 1: Electrically powered suction equipment — Safety requirements (ISO 10079-1:1999)*

EN ISO 10079-2:1999, *Medical suction equipment — Part 2: Manually powered suction equipment (ISO 10079-2:1999)*

EN ISO 10079-3:1999, *Medical suction equipment — Part 3: Suction equipment powered from a vacuum or pressure source (ISO 10079-3:1999)*

EN ISO 10524-1, *Pressure regulators for use with medical gases — Part 1: Pressure regulators and pressure regulators with flow-metering devices (ISO 10524-1:2006)*

EN ISO 10524-3, *Pressure regulators for use with medical gases — Part 3: Pressure regulators integrated with cylinder valves (ISO 10524-3:2005)*

EN ISO 11197:2004, *Medical supply units (ISO 11197:2004)*

prEN ISO 14971, *Medical devices — Application of risk management to medical devices (ISO/DIS 14971:2006)*

prEN ISO 15002, *Flow-metering devices for connection to terminal units of medical gas pipeline systems (ISO/DIS 15002:2005)*

EN ISO 19054, *Rail systems for supporting medical equipment (ISO 19054:2005)*

EN ISO 20345, *Personal protective equipment — Safety footwear (ISO 20345:2004)*

IEC 60364-7-708, *Electrical installations of buildings — Part 7: Requirements for special installations or locations. Section 708 — Electrical installations in caravan parks and caravans*¹⁾

ISO 3795, *Road vehicles, and tractors and machinery for agriculture and forestry — Determination of burning behaviour of interior materials*

ISO 5128:1980, *Acoustics— Measurement of noise inside motor vehicles*

3 Terms and definitions

For the purposes of this document, the following terms and definitions apply.

3.1

patient and emergency patient

3.1.1

patient

person whose condition requires appropriately trained personnel to provide medical care and/or suitable transport

3.1.2

emergency patient

patient who through sickness, injury or other circumstances is in immediate or imminent danger to life unless emergency treatment and/or monitoring and suitable transport to diagnostic facilities or medical treatment is provided

3.2

ambulance

vehicle or craft intended to be crewed by a minimum of two appropriately trained staff for the provision of care and transport of at least one stretchered patient

3.3

types of road ambulances²⁾

3.3.1

type A: patient transport ambulance

road ambulance designed and equipped for the transport of patients who are not expected to become emergency patients.

Two types of patient transport ambulance exist:

type A₁: suitable for transport of single patient;

type A₂: suitable for transport of one or more patient(s) (on stretcher(s) and/or chair(s))

1) IEC/TC 64 “Electrical installations and protection against electric shock” is developing the revision of IEC 60364-7-708. The draft is presently at the DIS stage. The standard, when ready, will be published as the first edition of the new section 7-721 “Electrical installations in caravans and motor caravans”.

2) Road ambulances are road vehicles which comply with type approval for special use vehicles according to Directive 70/156/EEC in the last applicable amended version.

3.3.2

type B: emergency ambulance

road ambulance designed and equipped for the transport, basic treatment and monitoring of patients

3.3.3

type C: mobile intensive care unit

road ambulance designed and equipped for the transport, advanced treatment and monitoring of patients

3.4

net vehicle mass; unloaded mass

net vehicle mass according to 92/21/EEC modified of the road ambulance including the driver taken as 75 kg and all fixed installations

NOTE Loose portable patient handling, sanitary, medical and technical equipment is not included in net vehicle mass.

3.5

permissible gross vehicle mass

permissible total mass

vehicle mass comprising the net vehicle mass, the mass of sanitary, medical and technical equipment, the mass of passengers, taken as 75 kg per person, and any reserve mass

NOTE The permissible gross vehicle mass should be specified by the chassis manufacturer in accordance with Directive 70/156/EEC.

3.6

loading capacity

difference between the gross vehicle mass and the net vehicle mass

NOTE This represents the mass that may be distributed on the road ambulance such that the permissible wheel loads are not exceeded.

3.7

fixation system

item of equipment or medical device permanently secured direct or by use of a fixation kit to the vehicle

3.8

maintain system

bracket or other interface device used to secure a mobile or transportable item of equipment or medical device of the vehicle without the use of tools

4 Requirements

4.1 General requirements

4.1.1 General

The road ambulance shall comply with the requirements of Directive 70/156/EEC, and separate directives, for ambulances or corresponding national requirements for approval of vehicles.

Road ambulances equipment shall, when operated in normal use and maintained according to the instructions of the manufacturer, cause no safety hazard which could reasonably be foreseen using risk management procedures in accordance with prEN ISO 14971 and which is connected with their intended application, in normal condition and in single fault condition.

Annex B and C give an example of "test summery" and "certificate of compliance".

4.1.2 Maximum overall dimension

The maximum overall dimensions shall be in accordance with the following:

- length in accordance with Directive 92/21/EEC modified;
- height 3 000 mm (measured at net vehicle mass excluding flexible antenna);
- width in accordance with Directive 92/21/EEC modified.

4.1.3 Wheel arch clearance

Vehicle converters shall maintain the minimum wheel arch clearance specified by the chassis manufacturer.

4.2 Performance

4.2.1 Acceleration

A road ambulance loaded to permissible gross vehicle mass shall be able to accelerate from 0 km/h to 80 km/h within 35 s.

4.2.2 Braking

An original equipment manufacturer's anti-lock braking system shall be fitted.

4.2.3 Safety system

The vehicle should be fitted with a control system for stabilisation and a passive safety system.

NOTE Examples of a control system for stabilization are an electronic brake distribution system and traction control. Examples of a passive safety system could be an air bag, a collapsible steering column and an energy absorbing body structure.'

4.3 Electrical requirements

4.3.1 General

Electrical installations shall comply with those clauses of IEC 60364-7-708 which are applicable to ambulances.

NOTE 1 The reference to IEC 60364-7-708 does not apply to the original electrical equipment, which is already covered by the type approval of the base vehicle.

The vehicle shall be fitted with a visual and audible warning system to assist emergency passage.

NOTE 2 The visual and audible warning system is optional for type A ambulances according to national regulations.

4.3.2 Electromagnetic compatibility (EMC)

4.3.2.1 General

To minimize any risk to the safe operation of the complete ambulance and any of the equipment operated on or in the vehicle from the effects of electromagnetic influences created by the vehicle or its equipment, each item shall comply with the appropriate EMC regulation(s).

The complete operational vehicle shall consist of components, equipment or sub systems that are certified as conforming to the respective industry EMC regulations.

Additionally for the supply system of the medical equipment the EN 60601-1 and EN 60601-2 series shall apply.

4.3.2.2 Communication equipment

Communication equipment (e.g. radio installation) shall comply with national regulations.

4.3.2.3 Electric/electronic system and components

The vehicle’s electric/electronic system, components, sub systems and all permanently fixed equipments shall be e-marked in accordance with directive 72/245/EEC modified.

NOTE It is recommended that the electrical medical equipment can withstand the exposure of radiated RF field strength of 20 V/m, measured according to IEC 60601-1-2, be considered as the minimum acceptable limit.

4.3.3 Battery and alternator

Batteries shall be positioned to allow maintenance without removing the battery from its securing device. The construction of the battery and all connections to it shall be such as to prevent any possibility of an inadvertent short circuit.

For types A₂, B and C road ambulances the electrical system shall be capable of holding a reserve of electrical power for restarting the engine.

The characteristics of starter batteries shall comply with Table 1. The characteristics of additional batteries, if fitted, shall comply with Table 1.

NOTE 1 Additional batteries may be required to power the medical devices carried on board and the intended use of the ambulance.

The characteristics of the alternator shall comply with Table 1.

Table 1 — Minimum capacity/power

Type of road ambulance		A ₁	A ₂	B	C
Starter battery(ies)	Nominal voltage 12 V	54 Ah	54 Ah up to 4 seats and 80 Ah more than 4 seats in the compartment	80 Ah	80 Ah
	Nominal voltage 24 V	–	–	63 Ah (2 × 12 V)	63 Ah (2 × 12 V)
Additional ^b battery(ies)	Nominal voltage 12 V	–	–	80 Ah ^a	80 Ah
	Nominal voltage 24 V	–	–	63 Ah ^a (2 × 12 V)	63 Ah (2 × 12 V)
Alternator power		700 W	700 W	1 200 W	1 200 W
^a Recommended for special operational conditions. ^b Additional batteries shall have high cyclic stability (e.g. gel batteries) and of a sealed type.					

NOTE 2 When the engine is idling electrical stability should be maintained between electrical load and alternator output. In order to achieve this it may be necessary to fit an electrical load prioritisation device to the vehicle.

4.3.4 Electrical installation

4.3.4.1 In type B and C road ambulances there shall be a recessed externally mounted power connector to enable external power to be provided for operations such as the following:

- charging battery(ies);
- operating medical devices, when installed;
- operating a patient compartment heater, when installed;
- operating an engine preheater, when installed.

The connector for 110 V or 220/240 V, shall be a male connector and not interfere with the electrical and mechanical safety.

It shall be not possible to start the engine whilst it is connected to an external 220/240 V power supply unless an automatic mechanical disconnection is fitted.

If no automatic mechanical disconnection is fitted, the connector shall be on the driver's side.

The 110 V or 220/240 V circuit shall be protected either by an "earth leakage device" with a maximum setting of 30 mA or by a separate transformer. If the protection is given only by an "earth leakage device" there shall be a label near the plug that reads as follows: "CAUTION! CONNECT ONLY TO AN AUTHORIZED SOCKET."

4.3.4.2 The patient's compartment shall be fitted with the minimum number of connections as given in Table 2. For these connections a permanent power supply shall exist.

Table 2 — 12 V connections for medical devices in patient's compartment

Type of road ambulance	A ₁	A ₂	B	C
Minimum number of connections	2	2	4	4

4.3.4.3 Any additional electrical systems fitted to the base vehicle shall be separate from the base vehicle electrical system and the body or chassis shall not be used as an earth return for additional circuits.

All circuits in the additional system(s) shall have separate overload protection³⁾. All circuits shall be well defined and cables clearly marked at the connection points and at a maximum of 1m intervals along its length.

The system shall have enough circuits and be so constructed that when/if a circuit fails all illumination or medical technical equipment can be switched to an alternative power source.

4.3.4.4 The wiring and, where applicable conduits, shall withstand vibrations. No wiring shall be located in or pass through conduit intended for medical gas installation. The wiring shall not be loaded higher than that stated by the wire manufacture.

³⁾ Overload protection may consist of either fuses or so called Electronic Management Control systems.

4.3.4.5 Where there are different voltage systems, the connections shall be non-interchangeable.

4.4 Vehicle body

4.4.1 Fire safety

All interior materials shall have a burning rate of less than 100 mm/min when tested in accordance with ISO 3795.

4.4.2 Driver's seat configuration

For all types of road ambulances the ergonomic space of the drivers compartment and of the seat adjustment as approved by the base vehicles manufacturer shall not be reduced.

4.4.3 Minimum loading capacity

The minimum loading capacity shall be in accordance with Table 3.

Table 3 — Minimum loading capacity (persons)

Type of road ambulance	A ₁	A ₂	B	C
Number of seats and/or stretcher facilities (in addition to the drivers seat)	3	4	3	4 5 ^a
^a With two stretchers.				

4.4.4 Bulkhead

A full bulkhead⁴⁾ or a bulkhead with a door shall separate the driver's compartment from the patient's compartment. Where a door is fitted, it shall not be possible to drive the vehicle with the door in the open position. This door shall be secured against opening if the road ambulance is in motion.

One or two windows with a minimum separation of 100 mm shall be provided in the bulkhead made of material complying with the requirements of Directive 92/22/EEC modified. The windows shall allow direct visual contact with the driver. The opening area of the window shall have a maximum area of 0,12 m². It shall be secured against self-opening and shall have an adjustable blind or other means of preventing the driver being disturbed by the light of the patient's compartment.

4.4.5 Openings (doors, windows, emergency exits)

4.4.5.1 General

There shall be a minimum of two openings – one at the rear (door/tailgate) and one at the side (door/window) of the patient's compartment.

All openings shall have seals to protect against the ingress of water.

All openings shall comply with the minimum dimensions set out in Table 4.

⁴⁾ Also called a "partition wall".

Table 4 — Minimum opening dimensions in the patient compartment

Type of road ambulance		A ₁ ^a mm	A ₂ ^a mm	B mm	C mm
Side opening	Height ^c	b	800	1 200	1 400
	Width ^c		600	660	660
Rear opening	Height	900	900	1 200	1 500
	Width	900	900	1 050	1 050
<p>^a Corner radius of conversions which reduce the opening area by less than 10 % are permitted.</p> <p>^b The dimensions provided by the original manufacturer shall not be reduced.</p> <p>^c If it is a window, the height and width dimensions may be interchanged.</p>					

See EN 1865 for stretcher dimensions which should be taken into account.

4.4.5.2 Doors

Each external door of the patient's compartment shall be fitted with a security system which enables the following:

- a) lock and unlock from inside without use of a key⁵⁾;
- b) lock and unlock from outside with use of a key⁵⁾;
- c) unlock from the outside using a key⁵⁾ when the door is locked from the inside.

NOTE This security system may be integrated with an optional central locking system.

The patient's compartment doors shall be capable of being positively restrained in the open position.

An audible and/or visual signal shall warn the driver when any door is not completely closed when the vehicle is in motion.

4.4.5.3 Windows

In the patient's compartment, there shall be a minimum of two external windows. There shall be one on each side or one on one side and the rear.

The windows shall be positioned or screened to ensure patient's privacy when required. Windows shall be made of material complying with the requirements of Directive 92/22/EEC modified.

4.4.6 Loading area

The loading area dimensions shall be in accordance with Table 5.

⁵⁾ The key can be a mechanical or non-mechanical device.

Table 5 — Loading area dimensions

Type of road ambulance		A ₁	A ₂	B	C
Tailgate height (in the open H_2 minimum position) (see Figure 1) ^a		1 800 mm	1 800 mm	1 900 mm	1 900 mm
Loading angle (stretcher)	maximum	16° ^b	16° ^b	16° ^b	16° ^b
Loading height (stretcher)	When the patient is manually loaded or unloaded on the stretcher, the centre of the stretcher handles shall be no more than 825 mm above ground level. The maximum height of either the floor or the loading holding assembly above ground level shall not exceed 750 mm at net vehicle mass plus loose equipment.				
^a	From ground to lowest point of fully opened tailgate at gross vehicle mass.				
^b	The loading angle shall be kept as low as possible.				

Where a ramp or lift is installed between ground level and vehicle floor level it shall be covered with a anti-slip surface and capable of taking a constant load of 350 kg. In the event of the power failure the loading device shall be capable of being operated manually.

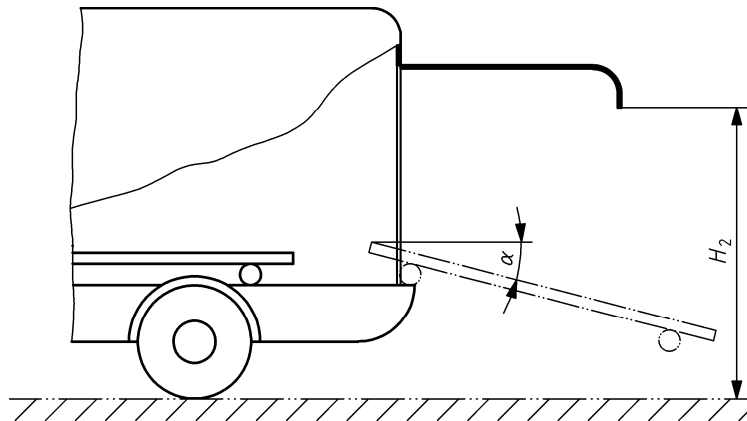

Figure 1 — Tailgate height (in the open position)

4.5 Patient's compartment

4.5.1 General

The patient's compartment shall be designed and constructed to accommodate the medical devices listed in Tables 9 to 19 in accordance with the vehicle type.

The ceiling, the interior side walls and the doors of the patient's compartment shall be lined with a material that is non-permeable and resistant to disinfectant.

The edges of surfaces shall be designed and/or sealed in such a way that no fluid can infiltrate. If the floor arrangement does not allow fluids to flow away, one or more drain with plugs shall be provided.

Exposed edges that could come into contact with the occupant's hands, legs, head etc., during normal use shall have a radius of curvature of not less than 2,5 mm except in the case of projections of less than 3,2 mm, measured from the panel. In this case, the minimum radius of curvature shall not apply provided the height of the projection is not more than half its width and its edges are blunted.

All installations in the patient compartment above 700 mm shall not have sharp exposed edges and shall terminate in rounded edges. A sharp exposed edge is defined as an edge of a rigid material having a radius of curvature of less than 2,5 mm.

Edges that can be contacted by using the apparatus and procedure described in 5.4 shall have an edge with radius of curvature greater than or equal to 2,5 mm or shall be made from a non rigid material. Medical equipment and their holding devices (for example stretchers, platforms, suction units etc.) are excluded.

Drawers should be secured against self-opening and where lockers are fitted with doors that open upwards they should be fitted with a positive hold open mechanism. Type B and C road ambulances shall be equipped with a lockable drugs compartment with security lock.

Floor coverings shall be chosen that will provide adequate grip for the attendant including when wet and should be durable and easy to clean.

Type B and C road ambulances shall be fitted with a hand-holding device positioned above the stretcher. For type C the hand-holding device shall be positioned along the longitudinal axis.

If the patient's compartment is to be equipped with a non-foldable sedan chair as defined in EN 1865, space shall be provided with a width of at least 600 mm measured at elbow height and a ceiling height above the seat squab of at least 920 mm (see Table 7, footnote a).

Vehicle maintenance equipment (e.g. spare wheel and tools) shall not be accessible from within the patient's compartment.

4.5.2 Patient's compartment dimensions

4.5.2.1 General

The dimensions relate to the patient's compartment with lining. To achieve only structural solidity a reduction of the dimensions of up to 5 % is acceptable in limited areas; door openings excluded.

4.5.2.2 Patient's compartment dimensions for type A₁, A₂ and B road ambulances

The patient's compartment shall comply with the minimum dimensions set out in Figures 2 to 4 (without cupboards, seats, medical devices and equipment).

W = width measured from RH-side to LH-side, except the roof curvature;

L = length measured from rear to bulkhead at height of stretcher;

H = height, measured from floor to roof;

X = height of stretcher holding assembly to roof measured in the middle of the longitudinal axis of the stretcher;

h_1 = height between centre of seat and roof;

h_2 = height between centre of seat and floor covering.

Dimensions in millimetres

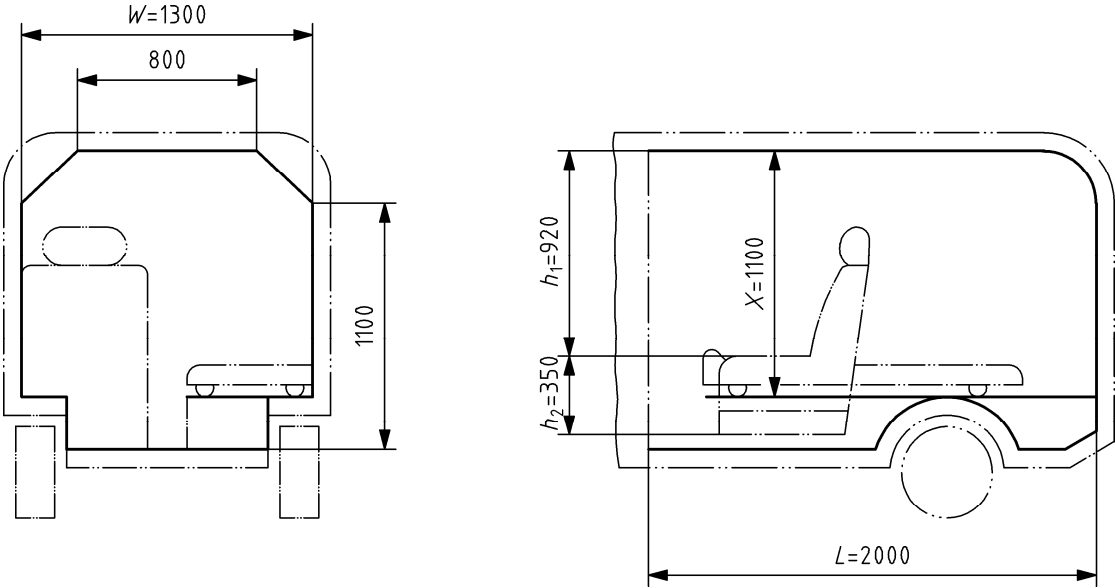
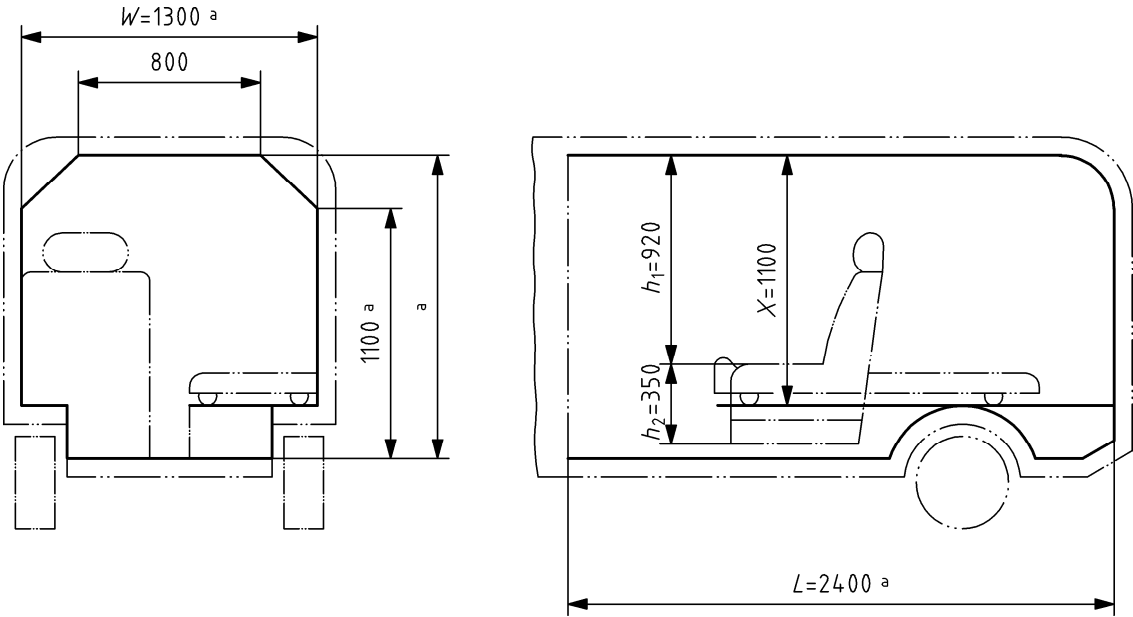

Figure 2 — Patient's compartment dimensions for type A₁ (schematic)

Dimensions in millimetres



^a Dimensions for Type A₂ with more than four seats in the patient's compartment. The length (L) shall be 3 100 mm, width (W) 1 500 mm. From a heights of 1 500 mm to 1 750 mm the sides shall have a radius no greater than 250 mm. The height (H) shall be 1 750 mm.

Figure 3 — Patient's compartment dimensions for type A₂ (schematic)

Dimensions in millimetres

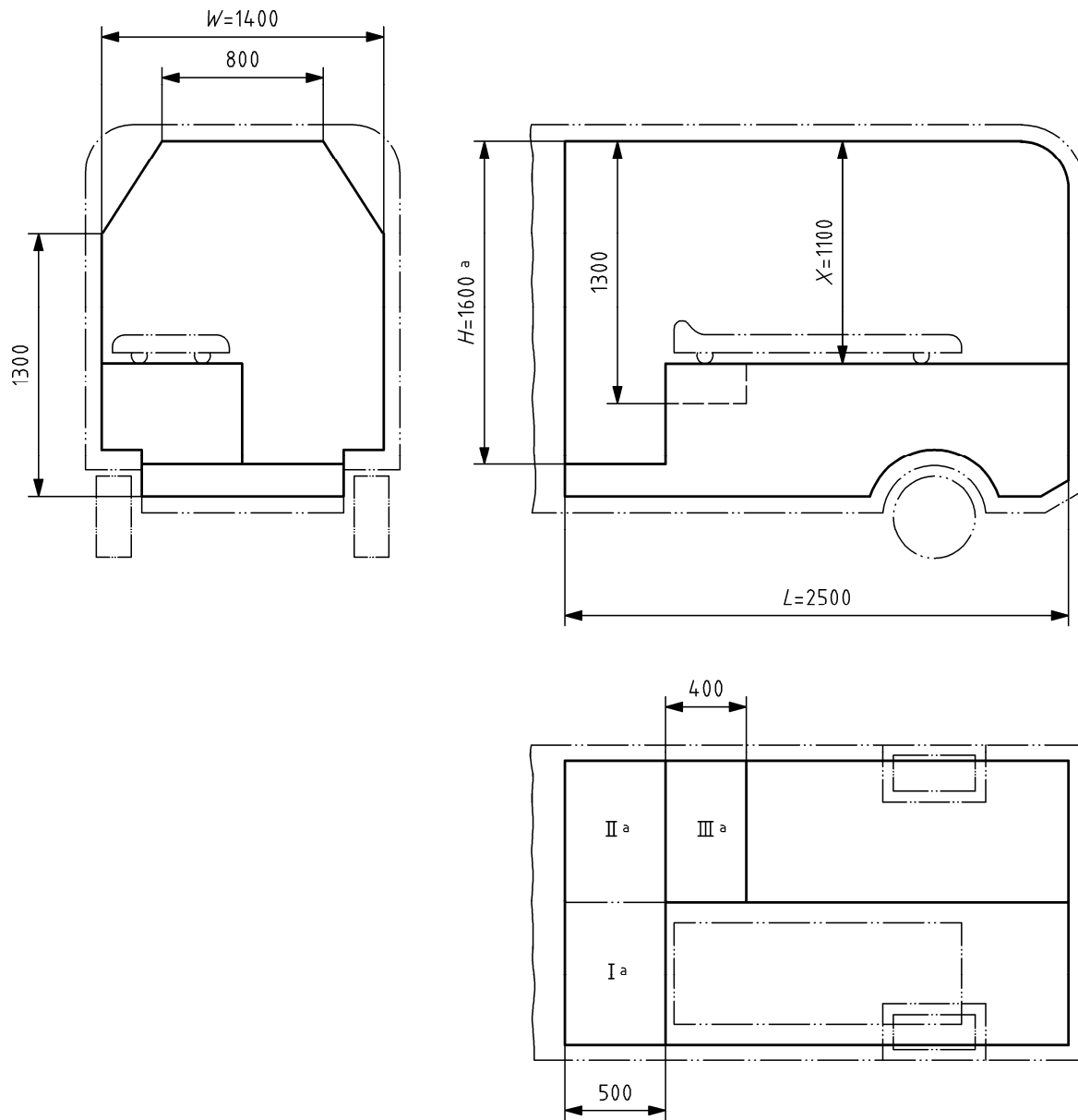

- a Area I
When it is necessary to facilitate emergency treatment there shall be a minimum of 500 mm between the lining of the bulkhead and the head-end part of the stretcher frame or stretcher platform measured in the mid-axis and at the height of the stretcher. A minimum height of 1 600 mm shall be provided.
- Area II
A minimum height of 1 600 mm shall be provided.
- Area III
A flat and horizontal surface of a minimum length of 400 mm shall be provided alongside the stretcher from the head-end part of the stretcher frame. A minimum height of 1 300 mm shall be provided.

Figure 4 — Patient's compartment dimensions for type B (schematic)

4.5.2.3 Patient's compartment and treatment area dimensions for type C

In type C road ambulances the patient's compartment shall be large enough to incorporate the treatment area⁶⁾ provided with dimensions as set out in Figure 5. Any protrusions into the treatment area shall be designed and constructed to fold away to provide these minimum dimensions. A seat (in stored position) and the medical technical equipment operated from this seat may intrude into the treatment area as follows:

- in this case the maximum intrusion shall be 125 mm at the head end of the stretcher
- or 125 mm on one side or a sum of 125 mm on both sides.

Verification of conformity of dimension of the treatment area shall be made when the stretcher is placed in the mean position of the treatment area.

h = A working height of the stretcher surface (excluding mattress) between 400 mm (minimum) and 650 mm (maximum) shall be ensured.

R = 500 mm (maximum), where R is the radius.

6) Also called "ergonomic space".

Dimensions in millimetres

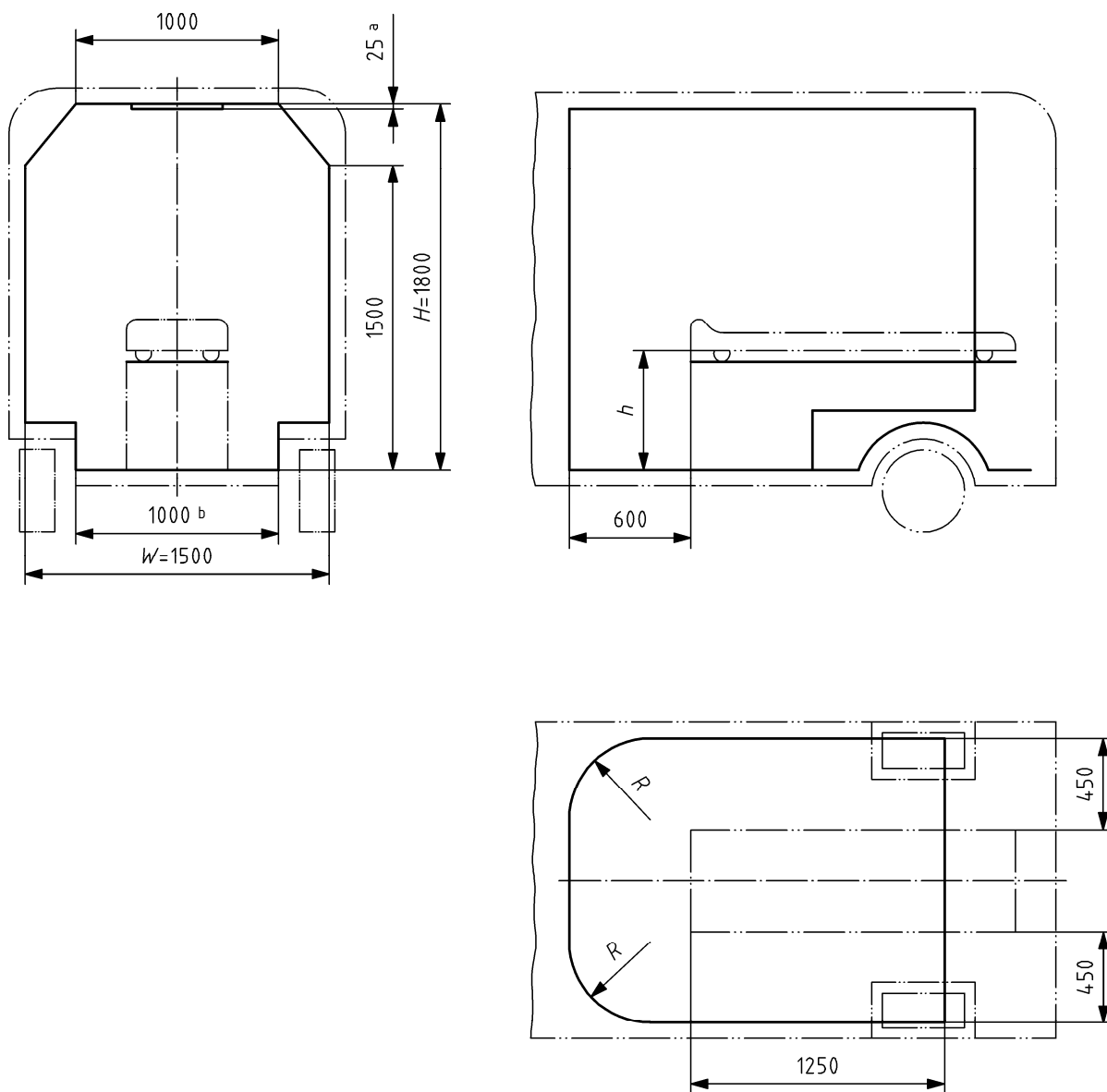

- ^a Reduced (25 mm maximum) in the roof area over the stretcher.
- ^b Where the height of the wheel arch exceeds 400 mm, the clearance width between the wheel arches above 400 mm shall not be less than 1 250 mm.

Figure 5 — Treatment area dimensions for type C

4.5.3 Patient and attendant seating

The minimum number of patient and attendant seats shall be as given in Table 6.

Table 6 — Number of patient and attendant seats

Type of road ambulance		A ₁	A ₂	B	C
Minimum number		1	2	2	2
Position(s)	on one side of the stretcher	1	1	–	–
	on one side of the stretcher upper $\frac{2}{3}$ end	–	–	1	1
Position(s) at head or side of stretcher		–	1 a	1	1
a Only when fewer than four seats.					

The seats shall comply with the minimum dimensions set out in Table 7.

Table 7 — Minimum dimensions for seating

	Single seat (patient) mm	Single seat (attendant) mm	Folding seat (attendant) mm
Width	450	450	450
Depth	400	330	330
Height above seat ^a	920	920	920
Thickness of upholstery	50	50	50
a Measured vertically above and in the middle of the 75 kg loaded seat.			

NOTE Where possible the seat height should be adjustable.

Seats fitted in accordance with Tables 6 and 7 shall be installed in either forward or rear-facing positions. Head restraints shall be fitted in accordance with Directive 78/932/EEC. Backrests shall be constructed to a minimum dimension of 300 mm × 100 mm, the upholstery of which shall be a minimum thickness of 20 mm.

Seats for patients and attendants shall not be permanently fixed in a side-facing position.

4.5.4 Ventilation and anaesthetic gas scavenging systems

4.5.4.1 Ventilation system

There shall be a ventilation system which shall provide a minimum of 20 air changes per hour when the vehicle is stationary.

4.5.4.2 Anaesthetic gas scavenging system (AGSS)

If the ambulance is intended to be used with delivery systems for anaesthetic gases e.g. N₂O or anaesthetic agent vapour it shall be equipped with an AGSS to make sure that the maximum permissible level of air contamination is not exceeded. This level is to be found in national or regional regulations.

NOTE Examples of an AGSS system can be found in EN 737-1 and prEN ISO 7396-2.

4.5.5 Temperature system

4.5.5.1 Heating

In addition to the heating of the driver's compartment there shall be an independent adjustable system as follows:

- heating for type A and B road ambulance;
- fresh air heating for type C road ambulances.

This system shall be such that given an outside and inside temperature of $-10\text{ }^{\circ}\text{C}$, or in extremely cold zones a temperature of $-20\text{ }^{\circ}\text{C}$, the heating up to at least $5\text{ }^{\circ}\text{C}$ shall not take longer than 15 min. After 30 min a temperature of at least $22\text{ }^{\circ}\text{C}$ shall be reached in the patient's compartment. The inside temperature shall be measured in the centre of the stretcher(s) and at the mid point from the heater outlets (if several outlets are available).

The heating shall be controlled by an adjustable thermostat or by an electronic climate control system. The actual temperature shall not vary from the set temperature by more than $5\text{ }^{\circ}\text{C}$.

The heating system shall be capable of meeting the performance criteria with the ventilation system switched off and the heating system set to re-circulate the air in the patient's compartment.

The installation of the system shall not encourage exhaust gases entering the patient's compartment.

4.5.5.2 Cooling

A cooling system is optional. Where a cooling system is fitted the following requirement are recommended.

The cooling system should be such that, given an outside and inside temperature of $32\text{ }^{\circ}\text{C}$, the cooling down to at most $27\text{ }^{\circ}\text{C}$ in the patient's compartment should not take longer than 15 min. After 30 min a temperature of at most $25\text{ }^{\circ}\text{C}$ should be reached. The inside temperature should be measured in the centre of the stretcher(s) and at the mid point from the cooling outlets (if several outlets are available).

The installation of the system shall not encourage exhaust gases entering the patient's compartment.

4.5.6 Interior lighting

Natural colour balance lighting shall be provided as set out in Table 8.

NOTE The colour temperature of the light will change the appearance of skin and organs. Therefore it's important that the interior lighting is suitable for patient care during transport. It is believed that it's not necessary in ambulance use to define "daylight" or "natural colour balance" in a more exact way other than the colour temperature. Regarding the colour temperature a comparison can be that examining lights in hospitals are normally between 3 800 to 4 300 degrees Kelvin.

In type C there shall be an additional light within the treatment area with a minimum of 1 650 lx. It shall be measured at the stretcher surface in its lowest position. The minimum distance of the measurement shall be 750 mm below the light and in an area with a minimum diameter of 200 mm.

Table 8 — Patient's compartment illumination

Type of road ambulance		A ₁ lx	A ₂ lx	B lx	C lx
Patient area (stretcher)	minimum:	100	100	300 ^a	300 ^a
Surrounding area	minimum:	30	30	50	50
^a Additionally there shall be a facility for switching the lighting level down to 150 ₀ ⁺⁵⁰ lx.					

Light levels shall be measured along the central longitudinal axis of the stretcher at the head, mid-point and foot position with the stretcher in its normal position for transportation in the ambulance.

4.5.7 Interior noise level

The interior noise level across the vehicle speed range shall be such that when tested in accordance with 5.1 it shall not exceed the maximum graphical line resulting from coordinates 70 dB(A) at 60 km/h or 40 % of the maximum speed, whichever is lower, to 78 dB(A) at 120 km/h or 60 % of the maximum speed, whichever is lower. A deviation of up to 3 dB(A) of the measured sound pressure level is permissible, within any vehicle type.

Noise measurements shall be made using the most appropriate gear for the speed being examined as determined by the base vehicle manufacturer.

4.5.8 Holding system for infusion

A holding system shall be provided to support two vertically fixed infusions in such a way as to use the maximum available height above the stretcher holding assembly. It shall be possible to position the infusions for use at either end of the stretcher holding assembly. The infusion mounting shall have a minimum capacity of 5 kg and be able to hold two bags of fluids independent of each other and shall be designed to minimise oscillation.

4.5.9 Mounting systems

Permanent seats and their anchorages in the patients' compartment, designed for use by patients and attendants when the ambulance is in motion, shall comply with the requirements of Directive 74/408/EEC modified. The seat belts anchorages of such seats shall comply with the requirements of directive 76/115/EEC modified. The seat belts shall comply with the requirements of directive 77/541/EEC modified. The forward facing seats be fitted with three-point seat belts of the type Ar4m

Head restraint shall be fitted in accordance with directive 78/932/EEC.

All persons and items e.g. medical devices, equipment and objects normally carried on the road ambulance shall be restrained, installed or stowed to prevent them becoming a projectile when subjected to accelerations/decelerations of 10 g in the forward, rearward, left, right and vertical directions.

When subjected to these accelerations/decelerations, the distance travelled by a person or item shall not endanger the safety of persons on the road ambulance.

After being subjected to these accelerations/decelerations:

prEN 1789:2006 (E)

- a) no items shall have sharp edges or endanger the safety of persons in the road ambulance;
- b) the maximum distance the stretcher and any item attached to either the holding assembly or stretcher may travel shall be no more than 150 mm. The displacement of the patient during the test may exceed 150 mm;
- c) it shall be possible to release all persons in the road ambulance without the use of equipment not carried on the road ambulance.

All tested lockers, rails and non dedicated storage locations or storage devices shall be labelled to show the total maximum permissible weight allowed.

5 Testing

5.1 Testing of the interior noise level

The measurements of the interior noise level in the patient's compartment shall be taken under the conditions given in ISO 5128:1980 with the following exceptions:

- the road ambulance shall be provided with the permanently installed equipment specified in this European Standard;
- contrary to the minimum tyre wear of 300 km specified in ISO 5128:1980, 8.1 new tyres without wear may be used;
- apart from the requirements in ISO 5128:1980, 8.3 the stretcher trays shall be in the normal position according to the manufacturer's recommendations;
- the measurement shall be made at a constant speed in accordance with ISO 5128:1980, 8.4.1 b);
- the measurements in accordance with ISO 5128:1980, 8.4.2 and 8.4.3 are not necessary;
- measurements shall only be taken in the patient's compartment and are required on all seats of the patient's compartment (including lying/carrying chair) according to ISO 5128:1980, 9.1 (but only in the longitudinal median plane of the seat) and on all stretchers according to ISO 5128:1980, 9.3;
- determination of octave and terz spectrums, according to ISO 5128:1980, 10.6 is not necessary;
- during the measurements, the audible warning and communication system shall be switched off.

5.2 Testing of the acceleration

The road surface of the test track shall be dry, level to within a longitudinal slope of 1 % and the wind velocity shall be a maximum 3 m/s.

The acceleration time shall be measured twice in each direction and the test runs completed in close succession. The result shall be the mean of the four readings.

5.3 Testing of maintain systems and fixations of the equipment in the patient's compartment

Verification of conformity to 4.5.9 shall be made when the stretcher(s)/medical device(s) and holding assembly is placed in the mean position of all possible positions available.

Appropriate verification shall be carried out. It may be done by calculation, static or dynamic testing depending on the individual technical problem. The method of verification shall be approved by a notified body.

NOTE The notified body which has to confirm the compliance with 4.5.9 according to 5.3 of EN 1789:2007 should

- a) be acknowledged by government authorities according to article 14 of the directives 70/156/EEC and should be competent in the three fields of static testing, dynamic testing and calculation in order to judge which method is appropriate for the verification of the individual technical problem;
- b) have an acknowledgement for the directives 77/541/EEC and 74/408/EEC, in case of impact test also for directives 96/79/EC.

The sample submitted for test, shall be identical to or have the same characteristics and behaviour during test as would the production item or vehicle. Care shall be taken that no internal/external additional reinforcement through the rig will modify the behaviour during test.

The stretchers and chairs shall be loaded with a dummy (according to ECE-Regulation No. 16, Annex 7) which is then secured with the restraint system. The head end of the stretcher shall be fixed in a position of 15° measured from the horizontal. The lying area of the stretcher tray assembly (holding assembly) shall be in a horizontal position.

The stretcher shall be fixed on the stretcher's holding assembly. The sedan chair when provided shall also be fixed in its holder.

The impact tests can be carried out with the appropriate stretcher(s) or medical device(s) installed or stowed in the holding system(s) or with weights having the mass distribution and dimensions corresponding to the mass and dimensions of the stretcher(s) and device(s) intended to be installed on or stowed in the holding system.

In case of dynamic testing, the dynamic test shall be carried out using a patient's compartment assembly or a relevant part of the construction approved by the notified body and the following test method:

The test assembly shall be accelerated/decelerated in the longitudinal, transverse and vertical directions accordance with Figure 6. The impact speed shall be between 30 km/h and 32 km/h.

Test weights for use in lockers should be sand bags with weights in kg increments, with a tolerance of +10 % /-0 %.

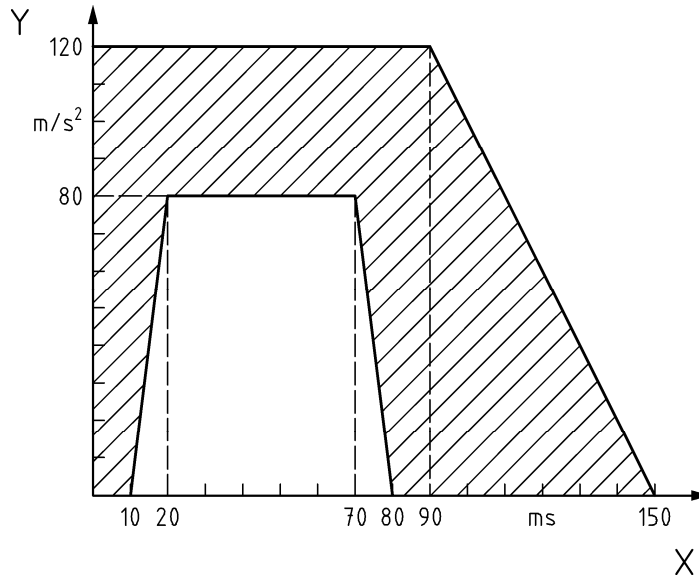
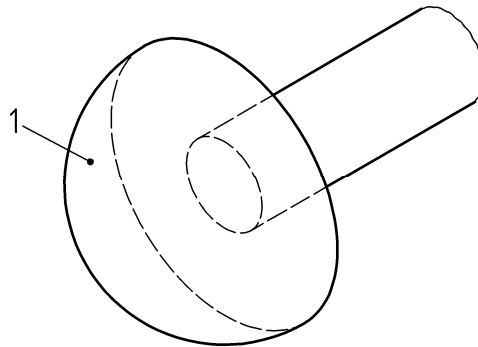

Figure 6 — Acceleration impulse

A test summary pro forma for completion by the test house is given in informative Annex B.

5.4 Testing of rounded edges

Conduct the test with a protrusion test ball shown in Figure 7 having a diameter of 165 mm.



Key

1 protrusion test ball

Figure 7 — Protrusion test ball

Doors and drawers shall be in closed position. Manoeuvre the protrusion test ball in all possible attitudes towards any rigid protrusion on the furniture above the plan. The plan is the horizontal plan located at 700 mm from the lowest point of the floor excluding steps or wells: if the protrusion test ball contacts the protrusion, that protrusion shall be considered to be an exposed edge and it shall comply with Figure 8.

If the protrusion test ball contacts the protrusion (see Figure 8), that protrusion shall be considered to be an exposed edge and shall comply with 4.5.1.

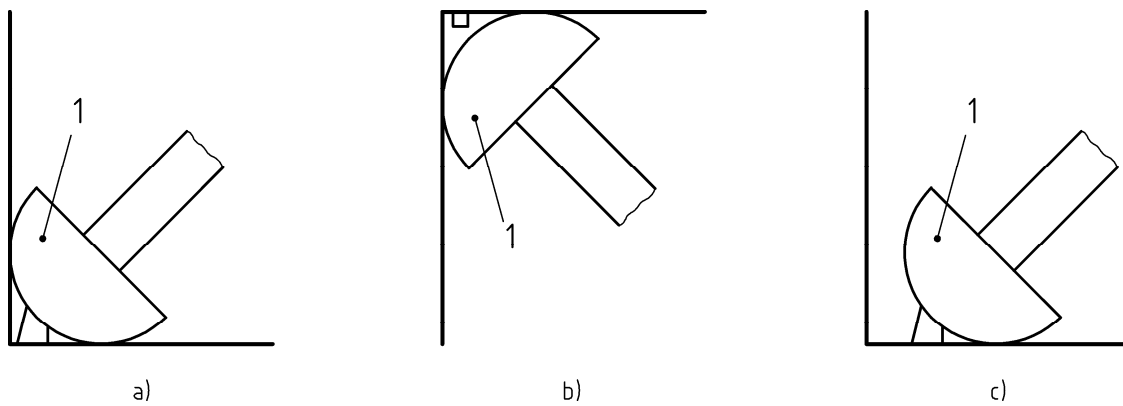
**Key**

- 1 protrusion test ball
- a protrusion shall comply
- b protrusion need not comply

Figure 8 — Examples of protrusions

6 Medical devices

6.1 Provision of medical devices

The road ambulance shall be designed and constructed to accommodate the items listed in the Tables 9 to 19 and provide the following levels of care:

- the patient transport ambulance (types A₁ and A₂) shall have basic professional equipment for first aid and nursing care;
- the emergency ambulance (type B) shall have equipment for basic treatment and monitoring of patients with the current methods of pre hospital care;
- the mobile intensive care unit (type C) shall have equipment for advanced treatment and monitoring of patients with the current methods of pre hospital intensive care.

6.2 Medical devices storage

All equipment required for a set procedure shall be stowed in a specified location. Essential equipment required for use outside the vehicle shall be easily accessible via normally used doors. All equipment shall be securely and safely stowed to prevent damage or injury whilst the vehicle is in motion (see 6.3.5).

6.3 Requirements for medical devices

6.3.1 General

The device shall be designed for use in mobile situations and in field applications⁷⁾.

If a medical device is designated as "portable" (except patient handling equipment according to Table 9) it shall be in accordance with EN 60601-1 and shall

- be possible to be carried by one person⁸⁾
- have its own built in power supply (where relevant);
- be capable of use outside the vehicle.

6.3.2 Temperature

6.3.2.1 Unless otherwise marked on the device, the device shall function as described in 6.3.2.2 and 6.3.2.3 when brought back to room temperature (20 °C) after storage in temperatures ranging from –30 °C to 70 °C.

6.3.2.2 Unless otherwise marked on the device, the device shall function throughout the temperature range from 0 °C to 40 °C.

6.3.2.3 Unless otherwise marked on the device, the device shall function for at least 20 min when placed in an environment at –5 °C after storage at room temperature (20 °C).

6.3.3 Humidity and ingress of liquids

Devices shall comply with EN 60601-1 and of particular device standards of the series EN 60601-2 where applicable.

6.3.4 Mechanical strength

6.3.4.1 General

Where there are not more stringent requirements for mechanical strength in particular devices standards exists, then the following mechanical strength requirements shall apply to medical devices for use in road ambulances.

6.3.4.2 Vibration and bump

After vibration tests and bump test in accordance with 6.4.1 the maintain system and device shall function within the tolerances specified by the manufacturer.

6.3.4.3 Free fall

If the medical device is fixed, as defined in EN 60601-1 it is exempted from the free fall test.

Medical devices which are taken out of holders and/or carried by hand shall be submitted to the free fall test according to 6.4.2 and shall then function within the tolerances specified by the manufacturer.

⁷⁾ See Directive 93/42/EEC.

⁸⁾ See Directive 90/269/EEC.

NOTE A medical device may consist of fixed and loose components, the free fall test applies to the loose components only.

6.3.5 Fixation of devices

The device shall be restrained by means of a fixation system.

The fixation system(s), maintain system(s) or storage system(s) shall hold the device to withstand accelerations or decelerations of 10 g longitudinal (forward, backward), 10 g transverse (left, right) and 10 g vertical.

Terminal units and electrical socket outlets shall not be used as part of the fixation system.

If rails systems are used, they shall comply with EN ISO 19054.

NOTE Rail systems consist of e.g. rail supports, rails, rail clamps, equipment mount holders, equipment mounts, equipment pin holders and equipment pins.

6.3.6 Electrical safety

All devices shall be selected and mounted so that no harmful influence to the electrical supply results.

6.3.7 User interface

Buttons, switches, indicators and controls shall be easily accessible and visible. SI units (except for blood pressure and airway pressure) and standardised graphical symbols where applicable shall be used.

6.3.8 Gas installation

6.3.8.1 Source of supply

The source of supply shall consist of one or more of the following (see also 5.1.3 of EN 737-3:1998):

- a) gas in cylinders, e.g. oxygen, air;
- b) non-cryogenic liquid in cylinders, e.g. N₂O, CO₂;
- c) cryogenic liquid in cylinders, e.g. oxygen;
- d) cryogenic liquid in stationary vessels, e.g. oxygen;
- e) non-cryogenic liquid in stationary vessels, e.g. N₂O, CO₂;
- f) an air compressor system;
- g) a proportioning system, e.g. oxygen and nitrogen;
- h) a vacuum system.

NOTE EN 737-3 may be used as guidance for designing the source of supply. See also 4.3.4.3.

6.3.8.2 Gas piping

Gas piping shall not pass through cupboards and compartments, all ducts for gas installations or gas piping shall be vented.

6.3.8.3 Stationary oxygen supply

The stationary oxygen supply shall comprise a source in accordance with Table 11 (under normal temperature and pressure) pressure regulators and terminal units or pressure regulators with flow metering devices.

6.3.8.4 Portable oxygen supply

The portable oxygen supply shall comprise a source in accordance with Table 11 (under normal temperature and pressure) and a pressure regulator with flow metering device.

6.3.8.5 Pressure regulators and flow metering devices

Pressure regulators and pressure regulators with flow metering devices shall conform to EN ISO 10524-1 or EN ISO 10524-3. The pressure regulators shall be directly connected to the source of supply.

Flow metering devices for connection to terminal units and for connection to flow-rate control units shall conform to prEN ISO 15002.

6.3.8.6 Terminal units

Terminal units shall comply with EN 737-1.

6.3.8.7 Pneumatic power supply

If the road ambulance is equipped with terminal units, the range of operating pressure shall be

— for compressed medical gases 400 kPa $^{+100}_0$ kPa;

— for vacuum ≤ 40 kPa absolute pressure

and the maximum allowable pressure change between the source of supply and the terminal units shall be

— for compressed medical gases 10 % at a flow of 40 l/min;

— for vacuum 20 % at a flow of 25 l/min.

6.3.8.8 Additional outlet connectors

For road ambulances complying with 6.3.8.7, one additional outlet connector (i.e. a terminal unit or a gas-specific connection point) complying with EN 737-1 shall be fitted in addition to the outlet connectors necessary for the devices intended to be normally used.

6.3.8.9 Test pressure

The gas piping shall withstand a pressure of 1 000 kPa, i.e. twice the maximum operating pressure of 500 kPa (see 6.3.8.7).

NOTE This pressure is also the maximum pressure supplied by pressure regulators complying with EN ISO 10524-1 and EN ISO 10524-3 in single fault condition.

6.3.8.10 Pin-index cylinder values

Pin-index outlet connections of cylinder values shall comply with EN ISO 407.

6.3.8.11 Flexible hoses

Flexible hoses for connecting medical devices to outlet connectors (i.e. terminal units or a gas-specific connection points) shall comply with EN 739. If flexible hoses are used between the pressure regulators and the terminal units, the requirements of EN ISO 11197 apply.

6.3.8.12 Alarms

If alarms are provided as part of the gas installation, they shall comply with Clause 6 of EN 737-3:1998.

6.3.9 Marking and instructions

Marking and instructions for use shall comply with EN 980 and EN 1041.

Operating and maintenance instructions, service records and any other appropriate regulations shall accompany the product. Standardised symbols should be used or it should be written in the native language of the area where the equipment is to be used.

6.3.10 Maintenance

The manufacturer shall supply instructions for carrying out preventive maintenance.

6.4 Mechanical strength – Test methods for medical devices for use in road ambulances

6.4.1 Vibration and bump test

The medical device shall be submitted to the following tests:

- vibration (sinusoidal) according to EN 60068-2-6, Test Fc;
- frequency range: 10 Hz to 150 Hz;
- amplitude/acceleration: $\pm 0,15$ mm/2 g;
- sweep rate: 1 octave/minute;
- number of sweep cycles: 4 in each axis;
- random vibration broad-band – reproducibility medium according to EN 60068-2-64, Test Fh;
- ASD⁹⁾ 10 Hz to 20 Hz: 0,05 g²/Hz;
- ASD 20 Hz to 150 Hz: 0,05 g²/Hz, –3 dB/Octave;
- total rms acceleration 1,6 g_{rms};
- duration/axis/mounting: 30 min;
- bump according to EN 60068-2-29, Test Eb;
- peak acceleration: 15 g;

⁹⁾ Acceleration Spectral Density.

prEN 1789:2006 (E)

- pulse duration: 6 ms;
- number of bumps: 1 000;
- direction: vertical, with the medical device in its normal operating position(s).

6.4.2 Free fall

The medical device shall, while functioning, be submitted to the following test:

- free fall according to EN 60068-2-32, Procedure 1;
- height of fall: 0,75 m;
- number of falls: 1 on each of the six surfaces.

6.5 List of equipment

The Tables 9 to 19 designate the minimum equipment carried by the road ambulances according to their type A₁, A₂, B and C.

Where national regulations for equipment are in conflict with Tables 9 to 19 the national regulations shall apply. Supplementary devices may be introduced depending on local requirements.

However, if it is common practice for the road ambulances to cross national borders, equipment according to Tables 9 to 19 shall be carried in accordance with the vehicle type.

For most items a specific quantity is given. "X" in the column indicates that quantity may be varied in accordance with the local needs of the country/district.

Where applicable the equipment shall be available across the full age range of patients.

The minimum mass including a mass reserve required for the listed sanitary, medical and technical devices in Tables 9 to 19 shall be as follows:

Road ambulance	type A ₁	100 kg;
	type A ₂	115 kg;
	type B	225 kg;
	type C	260 kg.

Table 9 — Type of patient handling equipment

No	Device	Standard	Type of road ambulances			
			A ₁	A ₂	B	C
1	Main stretcher/undercarriage	EN 1865	1	1	1	1
2	Pick up stretcher	EN 1865	–	–	1	1
3	Vacuum mattress	EN 1865	–	–	1	1
4	Device for conveying a seated patient ^a	EN 1865	1	1	1	X
5	Carrying sheet or transfer mattress	EN 1865	1	1	1	1
6	Long spinal board complete with head immobilizer and securing straps	EN 1865	–	–	X	X

^a Unless the main stretcher has the function of these devices.

Table 10 — Type of immobilization equipment

No	Device	Standard	Type of road ambulance			
			A ₁	A ₂	B	C
1	Traction device	–	–	–	X	X
2	Immobilization, set for fractures	–	–	–	1	1
3	Cervical upper spinal immobilization devices Cervical collar-set	–	–	–	1	1
4	Extended upper spinal immobilization Extrication devices or short spinal board (one of these)	–	–	–	1	1

Table 11— Type of ventilation/respiration equipment

No	Device	Standard	Type of road ambulance			
			A ₁	A ₂	B	C
1	Stationary oxygen ^a Minimum 2 000 l, (under normal temperature and pressure), flowmeter/ flowgauge with maxi- mum capacity of at least 15 l/min and regu- lating valve	EN 737-1:1998	X	X	1	1
	quick connection	EN 737-1:1998	–	–	1	1
2	Portable oxygen ^b Minimum 400 l, (under normal temperature and pressure), flowmeter/flowgauge with maximum capacity of at least 15 l/min and regulating valve	EN 737-1:1998	1	1	1	1
	quick connection	EN 737-1:1998	–	–	1	1
3	Resuscitator with oxygen inlet and masks and airways for all ages and oxygen resevoir	–	X	X	1	1
4	Mouth to mask ventilator with oxygen inlet	–	1	1	–	–
5	Non-manual suction device with a minimum pressure of –65 kPa with a minimum capacity of 1 l	EN ISO 10079- 1:1999 EN ISO 10079- 3:1999	–	–	1	1
6	Portable suction device	EN ISO 10079- 2:1999	1	1	1	1
^a A reduced capacity of 1 000 l may be fitted in type A ₁ and A ₂ road ambulances. ^b A reduced capacity of 200 l may be fitted in type A ₁ and A ₂ road ambulances.						

Table 12 — Type of diagnostics equipment

No	Device	Standard	Type of road ambulance			
			A ₁	A ₂	B	C
1	Manual B P Monitor, Cuff size 10 cm – 66 cm	–	–	–	1	1
2	Automatic B P Monitor, Cuff size 10 cm – 66 cm A doppler type shall operate accurately in the conditions of electrical interference and vibration specified in 4.3.1 and 6.3.4	–	–	–	X	X
3	Oximeter	EN ISO 9919	–	–	1	1
4	Stethoscope	–	–	–	1	1
5	Thermometer Minimum range 28 °C to 42 °C	EN 12470-1	–	–	1	1
6	Device for blood sugar determination	–	–	–	1	1
7	Diagnostic light	–	–	–	1	1

Table 13 — Type of drug

No	Device	Standard	Type of road ambulance			
			A ₁	A ₂	B	C
1	Pain relief	–	–	–	X	X

Table 14 — Type of infusion material or equipment

No	Device	Standard	Type of road ambulance			
			A ₁	A ₂	B	C
1	Infusion solutions, litre	–	–	–	4	4
2	Equipment for injections and infusions, set	–	–	–	2	2
3	Infusion system which is designed to allow the administration of fluid warmed to (37 ± 2) °C. This system is not required to be portable	–	–	–	1	1
4	Infusion mounting	–	1	1	2	2
5	Pressure infusion device	–	–	–	1	1

Table 15 — Type of equipment for managing of life-threatening problems

No	Device	Standard	Type of road ambulance			
			A ₁	A ₂	B	C
1	Defibrillator with rhythm and patient data recording ^a	EN 60601-2-4	1	1	1	1
2	Cardiac monitor ^a	EN 60601-2-4	–	–	1	1
3	External cardiac pacing ^a	EN 60601-2-4	–	–	X	1
4	Portable airways care system (p.a.c.s.) Manual resuscitator Mouth to mask ventilator with oxygen inlet Airways oro- or nasopharyngeal airway Aspirator Suction catheter	–	–	–	1	–
5	Portable advanced resuscitation system (p.a.r.s.) Contents of portable airways care system (p.a.c.s.) Infusion equipment – to include suitable venous indwelling cannulae Infusion administration sets Infusion solutions Adhesive fixing materials Intubation equipment – to include laryngoscope handle(s) with suitable blades Magill forceps Insertion stylets Endotracheal tubes with connectors Inflation tube clamp Inflation syringe Tube fixing material Stethoscope Drug administration equipment	–	–	–	–	1
6	Nebulization apparatus	EN 13544-1	–	–	1	1
7	Thorax drainage kit	–	–	–	–	1
8	Volumetric infusing device	–	–	–	–	1
9	Central vein catheters	–	–	–	–	1
10	Requirements for emergency and transport ventilators	EN 794-3	–	–	–	1
11	PEEP-valve, adjustable or set	–	–	–	–	1
12	Capnometer	EN 864	–	–	–	1

^a If desired two or more of these functions can be combined within one device.

Table 16 — Bandaging and nursing

No	Device	Standard	Type of road ambulance			
			A ₁	A ₂	B	C
1	Bedding equipment	–	1	2	1	1
2	Blankets	–	2	4	2	2
3	Material for treatment of wounds	–	1	1	1	1
4	Material for treatment of burns and corrosives	–	–	–	1	1
5	Re-plantation container to maintain the internal temperature at (4 ± 2) °C for at least 2 h	–	–	–	X	X
6	Kidney bowl	–	1	2	1	1
7	Vomiting bag	–	1	2	1	1
8	Bed-pan	–	X	X	X	X
9	Non-glass urine bottle	–	1	2	1	1
10	Sharps container	–	1	1	1	1
11	Gastric tube with accessories	–	–	–	X	X
12	Sterile surgical gloves, pairs	EN 455-1, -2	X	X	5	5
13	Non-sterile gloves for single use	EN 455-1, -2	100	100	100	100
14	Emergency delivery kit	–	X	X	1	1
15	Waste bag	–	1	1	1	1
16	Clinical waste bag	–	X	X	X	X
17	Non wovens stretcher sheet	–	1	1	1	1

Table 17 — Personal protection equipment (for each member of the crew for protection and to identify the staff as road ambulance personnel)

No	Device	Standard	Type of road ambulance			
			A ₁ ^a	A ₂ ^a	B ^a	C ^a
1	Basic protective clothing including high visibility reflective jacket or tabard	EN 471	1	1	1	1
2	Advanced protection wear	–	–	–	X	X
3	Safety/debris gloves, pairs	EN 420	1	1	1	1
4	Safety shoes, pairs	EN ISO 20345	X	X	1	1
5	Safety helmet	EN 14052	–	–	1	1
6	Personal protection equipment against infection	–	–	–	1	1

^a According to the numbers of crew member.

Table 18 — Rescue and protection material

No	Device	Standard	Type of road ambulance			
			A ₁ ^a	A ₂ ^a	B ^a	C ^a
1	Cleaning and disinfection material	–	1	1	1	1
2	Light rescue tools, set	–	–	–	X	X
3	Seat belt cutter	–	1	1	1	1
4	Warning triangle/lights	–	2	2	2	2
5	Spotlight	–	1	1	1	1
6	Fire extinguisher	EN 3-7	1	1	1	1

Table 19 — Communication

No	Device	Standard	Type of road ambulance			
			A ₁ ^a	A ₂ ^a	B ^a	C ^a
1	Mobile radio transceiver	–	1	1	1	1
2	Portable radio transceiver	–	–	–	1	1
3	Access to the public telephone network e.g. via the normal radio transmitter or by mobile (cellular) telephone	–	–	–	1	1
4	Portable alerting system, per person Can be included in portable radio receiver	–	–	–	1	1
5	Internal communication between driver and patient compartment	–	1	1	1	1

Annex A **(informative)**

Recognition

A.1 Recognition and visibility of ambulances

To enhance the recognition and visibility of the vehicle in daylight the base body colour should be yellow (RAL 1016) or white.

Where the white body option is selected additional fluorescent yellow or yellow (RAL 1016) or fluorescent red (RAL 3024) should be used on the external surface of the vehicles.

For night time visibility micro-prismatic reflective material should be applied.

With the exception of Red Cross societies or where the "Star of life" is locally registered, a blue reflective "Star of life" emblem (minimum size 500 mm) together with reflective letters, numerals or a symbol identifying the organization and the vehicle, should be applied to the roof of the ambulance.

With the exception of Red Cross societies or where the "Star of life" is locally registered, a blue reflective "Star of life" emblem should be applied to the sides and rear of the ambulance. The word "ambulance" or equivalent national translation should be applied in reflective upper case letters, a minimum of 100 mm high, in a colour contrasting with the background, to the side and rear of the ambulance and if possible on the front.

A.2 Recognition of personnel

Safety garments should conform to at least class 2 of EN 471.

With the exception of Red Cross societies or where the "Star of life" is locally registered, a blue reflective "Star of Life" emblem should be fixed to the garments. The garments should identify the designation of the wearer.

Annex B
(informative)

Test summary

This is to certify that ambulance compartment produced by
on the chassis
equipped as a (type A B or C) ambulance complies with EN 1789:2007, 4.5.9 and 5.3 Static and/or
dynamic tests have been carried from to
.....(dates)

Detailed data are to be found in test report number

Authorised designated official (name)

Signed

Date.....

Annex C (informative)

Certificate of compliance

We certify that the ambulance as described hereunder is compliant to the updated version of the standard EN 1789:2007

Name of the converter of the ambulance:

Base vehicle type (TVV type Variant and Version as described in Annex IX of 70/156 EEC):

Conversion:

Type (A/B/C):

General information:

Net vehicle mass (3.4):

Loading capacity (3.6):

Mass reserve (6.5):

Patient and attendant seating (4.4.3/4.5.3):

To ensure that we have carried out of the following tests:

Tested items	Completed by	Date	Test report	Result
Acceleration (4.1.2/5.2)				
EMC (4.3.2)				
Fire safety (4.4.1)				
Vehicle dimension (4.1.2/4.4.2/4.4.5)				
Ergonomic space (4.5.2)				
Loading angle (4.4.6)				
M1 seats (4.5.3)				
Ventilation system (4.5.4.1)				
Temperature system (4.5.5)				
Interior lighting (4.5.6)				
Interior noise level (4.5.7/5.1)				
Holding system for infusion (4.5.8)				
Maintain systems and fixations (4.5.9/5.3)				

A copy of the report of all the tests is at your disposal upon request.

It should be noted that the tests for Maintain systems and fixations (4.5.9/5.3) have to be carried out by a notified body.

The compliance has to be checked in accordance with the full standard, the tests listed here above are not a proof of the certification by themselves.

In (city/country), the (date)

Name and signature

Annex ZA (informative)

Relationship between this European Standard and the Essential Requirements of EU Directive 93/42/EEC concerning medical devices

This European Standard has been prepared under a mandate given to CEN by the European Commission and the European Free Trade Association to provide a means of conforming to Essential Requirements of the New Approach Directive 93/42/EEC concerning medical devices.

Once this standard is cited in the Official Journal of the European Communities under that Directive and has been implemented as a national standard in at least one Member State, compliance with the clauses of this standard given in Table ZA.1 confers, within the limits of the scope of this standard, a presumption of conformity with the corresponding Essential Requirements of that Directive and associated EFTA regulations.

Table ZA.1 — Correspondence between this European Standard and Directive 93/42/EEC concerning medical devices

Clause(s)/subclause(s) of this EN	Essential Requirements (ERs) of Directive 93/42/EEC	Qualifying remarks/Notes
whole standard	1, 2, 3, ,4, 7.1, 7.2	
4.2.1, 4.2.2	9.2	
4.3	9.1, 9.2, 9.3, 12.6, 13	
4.3.1	9.2, 12.5	
4.4.1	7.1, 9.3	
4.4.2 till 4.4.6	9.2	
4.5	7.3, 7.5	
4.5.5	12.7.5	
4.5.7	12.7.3	
4.5.8	9.2	
6.1, 6.2	9.1	
6.3.2	7.3, 9.2	
6.3.3	7.6	
6.3.4	9.2, 12.7.1, 12.7.2	
6.3.5	9.2	
6.3.6	4, 9.1, 9.2, 12.6	
6.3.7	10.1, 10.2, 10.3	
6.3.8	7.1, 7.3, 7.5, 9.1, 9.2, 9.3, 10.1, 10.2, 10.3, 12.3	
6.3.9	13, 13.6 b), h), p)	

WARNING — Other requirements and other EU Directives may be applicable to the product(s) falling within the scope of this standard.

Bibliography

- [1] Council Directive 70/156/EEC of 6 February 1970 on the approximation of the laws of the Members States relating to the type-approval of motor vehicles and their trailers
- [2] Council Directive 72/245/EEC of 20 June 1972 on the approximation of the laws of the Members States relating to the suppression of radio interference produced by spark-ignition engines fitted to motor vehicles
- [3] Council Directive 74/408/EEC of 22 July 1974 on the approximation of the laws of the Member States relating to the interior fittings of motor vehicles (strength of seats and of their anchorages)
- [4] Council Directive 76/115/EEC of 18 December 1975 on the approximation of the laws of the Member States relating to anchorages for motor-vehicle safety belts
- [5] Council Directive 77/541/EEC of 28 June 1977 on the approximation of the laws of the Member States relating to safety belts and restraint systems of motor vehicles
- [6] Council Directive 78/932/EEC of 16 October 1978 on the approximation of the laws of the Member States relating to head restraints of seats of motor vehicles
- [7] Council Directive 90/269/EEC of 29 May 1990 on the minimum health and safety requirements for the manual handling of loads where there is a risk particularly of back injury to workers (fourth individual Directive within the meaning of Article 16 (1) of Directive 89/391/EEC)
- [8] Council Directive 92/21/EEC of 31 March 1992 on the masses and dimensions of motor vehicles of category M1
- [9] Council Directive 92/22/EEC of 31 March 1992 on safety glazing and glazing materials on motor vehicles and their trailers
- [10] Council Directive 93/42/EEC of 14 June 1993 concerning medical devices
- [11] Directive 96/79/EC of the European Parliament and of the Council of 16 December 1996 on the protection of occupants of motor vehicles in the event of a frontal impact and amending Directive 70/156/EEC
- [12] Commission Directive 2004/104/EC of 14 October 2004 adapting to technical progress Council Directive 72/245/EEC relating to the radio interference (electromagnetic compatibility) of vehicles and amending Directive 70/156/EEC on the approximation of the laws of the Member States relating to the type-approval of motor vehicles and their trailers
- [13] ECE-Regulation No. 16; revision 3; uniform provisions concerning the approval of safety-belts and restraint systems for adult occupants of power- driven vehicles
- [14] prEN ISO 7396-2, *Medical gas pipeline systems — Part 2: Anaesthetic gas scavenging disposal systems (ISO/DIS 7396-2:2006)*